

ecostore Premium 2 Half Door Dual Digital Refrigerator, 670lt (-2/-2) - Remote

ITEM # _____

MODEL # _____

NAME # _____

SIS # _____

AIA # _____

727259 (ESP72HDRR)

Eco Store Premium Dual Refrigerator-670 lt 2 half doors (-2/-2°C)- Remote - 230 V/1N/50Hz

Short Form Specification

Item No. _____

Two half door refrigerator entirely constructed in 304 AISI stainless steel with bottom panel in anti-corrosive material. Large digital white-digit display with cabinet temperature display and setting, and possibility to select the desired levels of humidity. HACCP-compliant control with alarms and history. Frost Watch Control to defrost only when required with automatic evaporation of defrost water. Optiflow: back to front forced air flow and removable air conveyors provides even temperature distribution and fast cooling in any conditions. Fitted with 75 mm-thick cyclopentane insulating foam. On-site reversible door features lock and door microswitch to switch off the fan when the door is opened. Hidden evaporator to guarantee higher storage capacity and less corrosion problems. Remote refrigeration unit; ventilated operation; Internal LED light. Dual operating temperature: -2/+10°C -2/+10°C. CFC and HCFC free. R134a gas in refrigeration circuit. Supplied with n. 4x2/1GN Rilsan coated grids and n. 4 sets of 2 stainless steel grid runners. Prearranged to fit RS485 port to facilitate connection to a remote computer and integrated HACCP systems.

Main Features

- Right hinged two 1/2 door with heated frame.
- Large storage area suitable to contain 2/1 GN grids or shelves on anti-tilt runners.
- Optiflow: back to front forced air flow and removable air conveyors provide even temperature distribution and fast cooling in any conditions.
- Dual temperature type: -2 +10 °C/-2 +10 °C.
- Cabinet fitted with up to 75 mm thickness of cyclopentane insulation for best insulating performance with 100% environmental protection (thermal conductivity: 0,020 W/m* K).
- 60 mm-thick insulation covering the evaporator can be easily removed with a single operation.
- Prearranged to fit RS485 port to facilitate connection to a remote computer and integrated HACCP systems.
- Rilsan coated grids for improved protection.
- Connectivity ready for real time access to connected appliances from remote and data monitoring (requires optional accessory).
- Operating temperature can be adjusted from -2 to +10 °C to suit different food storage requirements.
- Performance guaranteed at ambient temperatures of +40°C (Climatic class 5).
- Large digital white-digit display with cabinet temperature display and setting, activation of turbo frost cycle (to rapidly cool warm loads) and possibility to activate manually the defrost cycle.
- Internal structure with 44 charging positions available to host grids, ensuring higher net capacity and a greater storage space.
- Possibility to select 3 different levels of humidity according with the type of food stored inside.
- Large digital white-digit display with cabinet temperature display and setting, and possibility to select the desired levels of humidity. Bluetooth technology included allows to keep HACCP historical data and download them through the app.
- Electrolux Professional Fridge Control APP make the life easier for our customers (available from April 2024):
 - Monitor safety of preservation process thanks to HACCP data & alarms for precise control
 - Save time and easy data management having the possibility to send the HACCP information in excel format directly to e-mail address
 - Quick operations: set the cabinet temperature/humidity/turbocooling and set date/hour

APPROVAL: _____

- Tropicalized unit.

Construction

- Constructed from the highest quality AISI 304 Stainless steel.
- Interior base with rounded corners, pressed from a single sheet.
- The rounded internal corners, the easily removable runners, grids and air conveyors allow for ease of cleaning and high hygiene standards.
- Stainless steel runners and supports easily disassembled.
- Anti-corrosion bottom avoids any damage that may be caused to the cabinet by aggressive detergents employed to clean the floors.
- Easy access to the main components for maintenance.
- Lockable door.
- Refrigerant type: R134a.
- Remote refrigeration unit.

Sustainability



- CFC and HCFC-free insulation.
- Interior LED light to save energy and for best internal visibility.
- Door switch stops the fan when door is opened to avoid cold air exiting the cell, thus saving energy.
- Removable triple-chamber balloon magnetic gasket to improve insulation and reduce energy consumption and ease of cleaning.
- Improved defrost and evaporator fan management - defrost type changes with temperature set-point: electric below +2°C while air convection defrost above +2°C, thus saving energy.
- Frost Watch Control: fully automatic defrost starts only when ice is actually building-up in the evaporator and adapt the defrosting duration to guarantee perfect ice removal while optimizing energy efficiency consumption.
- Automatic evaporation of the defrosting water by hot gas on the top for energy saving.
- R290 refrigerant to reduce green house and ozone depletion effects.
- Cleaning-free condenser: the structure of the wire frame condenser prevents dust and grease accumulation thus avoiding periodical cleaning operations and reducing energy consumption.
- CFC and HCFC free, highly ecological refrigerant type: R290 (ecological gas in foam: cyclopentane). Hydrocarbon refrigerant gas R290 for the lowest environmental impact (GWP=3), to reduce green house and ozone depletion effects.
- Cabinet certified as Class A in heavy duty working conditions (40°C-40% humidity) based on European Ecodesign directive.
- The label complies with the delegated regulation (UE) 2015/1094 of the commission of 5th may 2015.

Included Accessories

- 4 of 2/1GN grey rilsan grid with 2 runners PNC 881020

Front

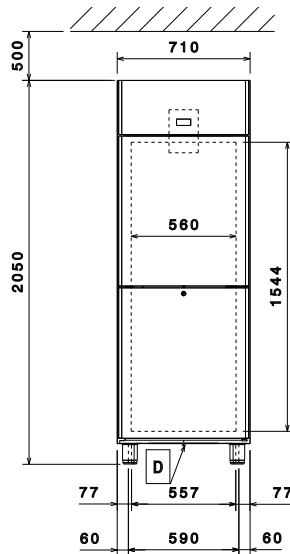

Side

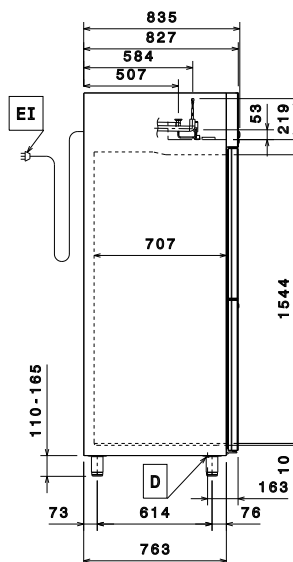

EI = Electrical inlet (power)
 RI = Refrigerant Inlet
 RO = Refrigerant Outlet

Top

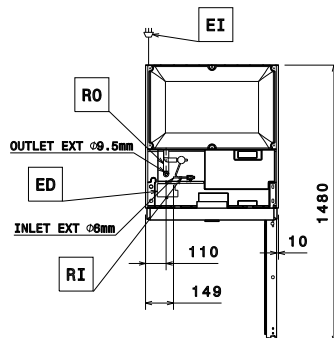

Electric

Supply voltage:

727259 (ESP72HDDR) 220-240 V/1 ph/50/60 Hz

Electrical power max.:

0.28 kW

Key Information:

Gross capacity:	670 lt
Door hinges:	2 Right
External dimensions, Width:	710 mm
External dimensions, Depth:	835 mm
External dimensions, Depth with Doors Open:	1480 mm
External dimensions, Height:	2050 mm
Number and type of doors:	2x1/2 Full
Number and type of grids (included):	4 - GN 2/1
Type of external material:	304 AISI
Type of internal material:	304 AISI
Internal panels material:	304 AISI
Number of positions & pitch:	40; 30 mm

Refrigeration Data

Control type:	Digital
Second Unit Refrigerant type:	R134a
Refrigeration type:	R134a;R513A
Suggested refrigeration power:	358 W
Suggested refrigeration power: (second unit):	358 W
Condition at evaporation temperature:	-10 °C
Condition at condensation temperature:	55 °C
Condition at ambient temperature:	32 °C
Connection pipes (remote) - outlet:	9.5 mm
Connection pipes (remote) - inlet:	6 mm

*Note:

ISO Certificates

ISO Standards: ISO 9001; ISO 14001; ISO 45001; ISO 50001

Sustainability

Refrigerant type: R134a